



使用说明书

Instructions for use

个人装备：救援、攀登、绳索、器材专业制造商
 Personal equipment: specialist manufacturers of rescue, climbing, ropes and fall protection devices



ENGLISH

Applic to static rope: HT-JL01
Manufacturer: HOATER (Hangzhou) Safety Technology Co., Ltd.
 3507, Xinghui Center, No. 723 Dayuan Road, Lin'an District, Hangzhou City, Zhejiang Province, China
Notified body for EU type examination and production control:
 APAVE SUDEUROPE SAS 8 rue Jean Jacques Vernazza - Z.A.C.Saumaty-Séon - CS 60193 - 13322 MARSEILLE CEDEX 16.

The rope is classed as a personal protective Equipment (PPE) by the European Regulation 2016/425 and has been shown to comply with this Regulation through the European Standard EN1891:1998.

Carefully read these instructions before using this rope

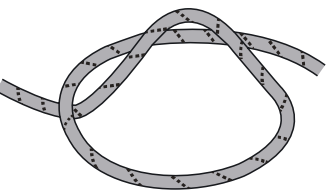

Model:HT-JL01
 Type:A
 Diameter:10.5mm
 Knotability:1.1
 Sheath slippage:0.3%
 Elongation 50-150kg:3.2%
 Shrinkage:0%
 Weight:73g/m
 The mass of the sheath Sp:35.5%
 The mass of the core C:64.5%
 Min number of falls: 5
 Impact Force:29.5kN
 Min.Tenacity with knots:15kN
 Used material: Polyamide

Limitations:

- Please consider the following application limitations before using this equipment:
1. The equipment shall not be used outside its limitations, or for any purpose other than that for which it is intended.
 2. The equipment shall only be used by a person trained and competent in its safe use.
 3. No more than one personal protective system may be connected at one time.
 4. Before use, the supervisors must consider about the risk of possible danger, a rescue plan needs to be established to deal with any emergencies that could arise during the work.
 5. During the use, user use equipment must under supervision.
 6. Ensure compatibility of all other products used with the equipment when assembled into a system.
 7. The user should carry out a pre-use check of the equipment, to ensure that it is in a serviceable condition and operates correctly before it is used.
 8. Withdraw the equipment from use if there is any doubt about its condition for safe use or if it has already arrested a fall, do not use it again until confirmed in writing by a competent person.
 - 9.The life span of the product is 10 years but inspection, annually is important to check if any damages have occurred during usage.
 10. If it has been subjected to a major fall or load,it must stop use.
 11. This equipment is should be treated as a personal issue item.

Field of application:

This equipment is personal protective equipment—EN1891:1998 type A static rope (low stretch kernmantel rope),and this product is designed to provide protection against the danger of falling from heights. This rope can be used for rope access,working positioning ,travel restraint,as well as rescue,caving or canyoning.It can also be used as a working rope or a safety rope .

Note: Type A ropes are more suitable for use in rope access and work positioning than

type B ropes.

If type B ropes are chosen, users should be aware that the level of performance will be less than that of type B; that greater care will be required in protecting against the effects of abrasion, cuts, general wear and tear etc., and than in use gerat care should be taken to minimise the possibility of a fall.

Warning:

This rope must not be loaded beyond its strength rating,nor be used for any purpose other than that for which it is designed. In particular, don't use them for load lifting.

Inspection:

1. Your safety is related to the integrity of your equipment.
2. Equipment used for work safety in accordance with EN 365 must be inspected by an expert in close observance of the instructions or by the manufacturer itself at least every 12 months and replaced if necessary.
3. Record the results of the inspection on your PPE inspection form(see form 1): type, model, trade name , identification number, manufacturer contact info , dates: manufacture, purchase, first use, Reason for entry (periodic examination or repair), defects noted, repairs carried out and other relevant information, name and signature of competent person, periodic examination next due date.
4. In general,The inspection must include:

An inspection of the product' s general condition: age,integrity, soiling proper composition.

Label inspection: Is the label present? Is the label legible? Is there a CE label? Can you read the Date of MFG?

Inspection of all individual parts for mechanical damage,e.g.: tears, rips, nicks, abrasion, deformation, ribbing,entangling, crushing.

Inspection of all individual parts for thermal or chemical damage, e.g.: melting, hardening.

5. Before each use visually check the condition of the sheath along the entire length of the rope. Make sure there are no cuts, burns, frayed strands, fuzzy areas, or signs of chemicals.

6. Carry out a tactile inspection of the core along the entire length of the rope, This allows you to detect areas where the core is damaged (hard spot, mushy area).

7. If the equipment has been subject to stress through a fall, it should be withdrawn from use immediately. If you have the slightest doubt, the product must be discarded or may only be used again if an expert has provided written confirmation that it is fit for use after examination.

8. During use: It is important to regularly monitor the condition of the product and its connections to the other equipment in the system. Make sure that all items of equipment are correctly positioned with respect to each other.

Compatibility:

1. Please ensure that the recommendations for use with other components are maintained: All other components of the working harness must be certified and comply with the relevant standards for PPE

2. Use ropes in accordance with EN 1891 must be used in systems in accordance with EN 341 (Descender Devices for Rescue), EN 358 (work positioning safety belt) or EN 363 (Personal Fall Protection Systems), i.e. for various rope-supported work. Please note that the surface of new, unused ropes can be very smooth and slippery. When using devices, please read the manufacturer' s information on the respective device.
3. Rope devices should be adjusted to the rope diameter.
4. Metal parts must not have any burrs or sharp edges that could damage the rope.

Any combination of equipment that affects the safe functioning of any single piece of equipment or the entire system puts you at risk too!

Precautions for use:

1. Type B ropes have a lower performance level than type A ropes;they are more susceptible to abrasion, cuts, normal wear... It is important to pay greater attention to reducing the potential for falls. Type A ropes are better suited than type B ropes for use in rope access and work positioning.
2. To prolong rope life (better sheath/corecohesion), soak it in water for 24 hours prior to first use. This removes lubricants and otherproducts used in manufacturing. Let the ropedry slowly. It will shrink by approximately 5 %(5 m for every 100 m).
3. Protected from chemicals, heat, abrasion, ultraviolet light, sharp edges that can

damage your rope.

4. Rubbing together of two ropes through karabiners or maillons induces heat which could result in rupture.

5. Avoid over-rapid abseiling or lowering which could burn the rope and accelerate sheath wear. The melting temperature of polyamide is 230 °C. This temperature may be attained during very rapid descents .

6. The temperature in which the rope is used must never exceed 80 °C .

7. To clean, rinse the rope with lukewarm water and wipe with a damp cloth. The wet rope should be left to dry before storage. The rope should dry naturally, not near a fire or other heat source.

8. To disinfect the rope, you may only use products that have no influence on the synthetic materials used. If you do not comply with these conditions, you put yourself at risk!

9. A rope swells with use and can shrink in length by up to 15 %. Regularly check the length of your rope.

10. A wet or icy rope is less abrasion-resistant. It is also harder to control in belay/rappe devices.

11. A knot at the end of the rope is a necessary precaution in a variety of situations (long rappel, poor visibility, fatigue...). Avoid descending too rapidly: risk of burns and accelerated wear of the rope.

12. To make a termination, tie a figure-eight knot at the desired location on the rope. We recommend a figure eight loop for your own rope terminations. There must be at least 10 cm of rope behind the knot. Please tie the knot correctly, as illustrated in Fig.1! Please note the route the load-bearing portion of rope takes (arrow). A different version will reduce the breaking load considerably.

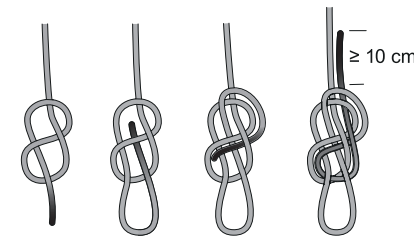

Fig.1 Detail of figure of eight knot

13. If free climbing is necessary when using the rope during rope-supported work, rescuing or speleology, you must use suitable ropes (e.g. dynamic mountaineering ropes in accordance with EN 892).

14. The system must include a reliable anchoring point (in accordance with EN 795,especially 12KN minimum strength) above the user.Avoid slack in any kernmantle rope with limited elongation between the user and the reliable anchoring point.

15. If a rope is cut into several lengths, mark the ends with the correct lengths and end-markings. The new lengths of rope must each be furnished with a copy of the Instructions for Use.

Application:

The rope shall be used in the following applications:

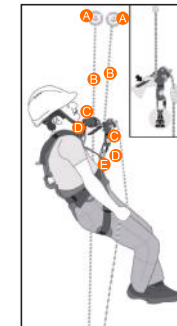

- key
- A. Anchor points (EN 795)
 - B. Ropes (EN 1891)
 - C. Descenders (EN 12841)
 - D. Connector (EN362)
 - E. Full body harness (EN361)

This rope must be used in conjunction with equipment which conform to the European standards (EN361-EN362 - EN795 - EN12841 etc.) and the user need make sure all recommendations of every equipment composing the fall arrest system are understood and applied.

Additional information:

1. This product meets the requirements of Regulation (EU) 2016/425 on personal protective equipment.,and IFU(instructions for use) will be attached to the coil/reel.
2. Before the product is used there must be a plan for rescue operations that takes into account

This rope must be used in conjunction with equipment which conform to the European standards (EN361-EN362 - EN795 - EN12841 etc.) and the user need make sure all recommendations of every equipment composing the fall arrest system are understood and applied.

Additional information:

1. This product meets the requirements of Regulation (EU) 2016/425 on personal protective equipment.,and IFU(instructions for use) will be attached to the coil/reel.
2. Before the product is used there must be a plan for rescue operations that takes into account all possible emergencies.During and before use, you must consider how to perform the rescue efforts safely and effectively.
3. Do not perform any rope-supported work if your physical condition could compromise your safety during normal use or in an emergency!
4. In a fall arrest system, it is essential to check the required clearance below the user before each use, in order to avoid hitting the ground or an obstacle in case of a fall. Avoid slack in the rope between the user and the anchor point.
5. According to EN 1891, no changes or additions to ropes are permitted and may only be performed by the manufacturer.The breaking load of the rope / rope with terminations applies only to force between one of the end the rope and the other. You should therefore never load a termination loop transversely (2 carabiners in a loop). Check the load on the rope in the selected configuration and never overload it. We recommend a safety factor of ≥ 7 .
6. Make sure that the anchor point is correctly positioned, in order to limit the risk and the length of a fall.
7. A fall arrest harness is the only device allowable for supporting the body in a fall arrest system.
8. The Instructions for Use for each item of equipment used in conjunction with this product must be followed.
9. The Instructions for Use must be provided to the user of this equipment, in the language of the country where the equipment is used. And make sure the markings on the product are legible.

Hoater Guarantee:

This product is guaranteed for 3 years against any faults in materials or manufacture . Exclusions from the guarantee: normal wear and tear, modifications or alterations , incorrect storage, poor maintenance, damage due to accidents, to negligence, or to improper or incorrect usage.



使用说明书

Instructions for use

个人装备：救援、攀登、绳索、器材专业制造商
 Personal equipment: specialist manufacturers of rescue, climbing, ropes and fall protection devices



ENGLISH

Applic to static rope: HT-JL02
Manufacturer: HOATER (Hangzhou) Safety Technology Co., Ltd.
 3507, Xinghui Center, No. 723 Dayuan Road, Lin'an District, Hangzhou City, Zhejiang Province, China
Notified body for EU type examination and production control:
 APAVE SUDEUROPE SAS 8 rue Jean Jacques Vernazza - Z.A.C.Saumaty-Séon - CS 60193 - 13322 MARSEILLE CEDEX 16.

The rope is classed as a personal protective Equipment (PPE) by the European Regulation 2016/425 and has been shown to comply with this Regulation through the European Standard EN1891:1998.

Carefully read these instructions before using this rope

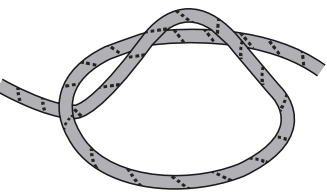

Model: HT-JL02
 Type: A
 Diameter: 11mm
 Knotability: 1.0
 Sheath slippage: 0.6%
 Elongation 50-150kg: 3.4%
 Shrinkage: 0%
 Weight: 81g/m
 The mass of the sheath Sp: 34.6%
 The mass of the core C: 65.1%
 Min number of falls: 5
 Impact Force: 30.4kN
 Min.Tenacity with knots: 15kN
 Used material: Polyamide

Limitations:

Please consider the following application limitations before using this equipment:

1. The equipment shall not be used outside its limitations, or for any purpose other than that for which it is intended.
2. The equipment shall only be used by a person trained and competent in its safe use.
3. No more than one personal protective system may be connected at one time.
4. Before use, the supervisors must consider about the risk of possible danger, a rescue plan needs to be established to deal with any emergencies that could arise during the work.
5. During the use, user use equipment must under supervision.
6. Ensure compatibility of all other products used with the equipment when assembled into a system.
7. The user should carry out a pre-use check of the equipment, to ensure that it is in a serviceable condition and operates correctly before it is used.
8. Withdraw the equipment from use if there is any doubt about its condition for safe use or if it has already arrested a fall, do not use it again until confirmed in writing by a competent person.
9. The life span of the product is 10 years but inspection, annually is important to check if any damages have occurred during usage.
10. If it has been subjected to a major fall or load, it must stop use.
11. This equipment is should be treated as a personal issue item.

Field of application:

This equipment is personal protective equipment—EN1891:1998 type A static rope (low stretch kernmantel rope), and this product is designed to provide protection against the danger of falling from heights. This rope can be used for rope access, working positioning, travel restraint, as well as rescue, caving or canyoning. It can also be used as a working rope or a safety rope.

Note: Type A ropes are more suitable for use in rope access and work positioning than

type B ropes.

If type B ropes are chosen, users should be aware that the level of performance will be less than that of type B; that greater care will be required in protecting against the effects of abrasion, cuts, general wear and tear etc., and than in use great care should be taken to minimise the possibility of a fall.

Warning:

This rope must not be loaded beyond its strength rating, nor be used for any purpose other than that for which it is designed. In particular, don't use them for load lifting.

Inspection:

1. Your safety is related to the integrity of your equipment.
2. Equipment used for work safety in accordance with EN 365 must be inspected by an expert in close observance of the instructions or by the manufacturer itself at least every 12 months and replaced if necessary.
3. Record the results of the inspection on your PPE inspection form (see form 1): type, model, trade name, identification number, manufacturer contact info, dates: manufacture, purchase, first use, Reason for entry (periodic examination or repair), defects noted, repairs carried out and other relevant information, name and signature of competent person, periodic examination next due date.
4. In general, The inspection must include:

An inspection of the product's general condition: age, integrity, soiling proper composition.

Label inspection: Is the label present? Is the label legible? Is there a CE label? Can you read the Date of MFG?

Inspection of all individual parts for mechanical damage, e.g.: tears, rips, nicks, abrasion, deformation, ribbing, entangling, crushing.

Inspection of all individual parts for thermal or chemical damage, e.g.: melting, hardening.

5. Before each use visually check the condition of the sheath along the entire length of the rope. Make sure there are no cuts, burns, frayed strands, fuzzy areas, or signs of chemicals.

6. Carry out a tactile inspection of the core along the entire length of the rope, This allows you to detect areas where the core is damaged (hard spot, mushy area).

7. If the equipment has been subject to stress through a fall, it should be withdrawn from use immediately. If you have the slightest doubt, the product must be discarded or may only be used again if an expert has provided written confirmation that it is fit for use after examination.

8. During use: It is important to regularly monitor the condition of the product and its connections to the other equipment in the system. Make sure that all items of equipment are correctly positioned with respect to each other.

Compatibility:

1. Please ensure that the recommendations for use with other components are maintained: All other components of the working harness must be certified and comply with the relevant standards for PPE

2. Use ropes in accordance with EN 1891 must be used in systems in accordance with EN 341 (Descender Devices for Rescue), EN 358 (work positioning safety belt) or EN 363 (Personal Fall Protection Systems), i.e. for various rope-supported work. Please note that the surface of new, unused ropes can be very smooth and slippery. When using devices, please read the manufacturer's information on the respective device.
3. Rope devices should be adjusted to the rope diameter.
4. Metal parts must not have any burrs or sharp edges that could damage the rope.

Any combination of equipment that affects the safe functioning of any single piece of equipment or the entire system puts you at risk too!

Precautions for use:

1. Type B ropes have a lower performance level than type A ropes; they are more susceptible to abrasion, cuts, normal wear... It is important to pay greater attention to reducing the potential for falls. Type A ropes are better suited than type B ropes for use in rope access and work positioning.
2. To prolong rope life (better sheath/core cohesion), soak it in water for 24 hours prior to first use. This removes lubricants and other products used in manufacturing. Let the rope dry slowly. It will shrink by approximately 5% (5 m for every 100 m).
3. Protected from chemicals, heat, abrasion, ultraviolet light, sharp edges that can

damage your rope.

4. Rubbing together of two ropes through karabiners or maillons induces heat which could result in rupture.

5. Avoid over-rapid abseiling or lowering which could burn the rope and accelerate sheath wear. The melting temperature of polyamide is 230 °C. This temperature may be attained during very rapid descents.

6. The temperature in which the rope is used must never exceed 80 °C.

7. To clean, rinse the rope with lukewarm water and wipe with a damp cloth. The wet rope should be left to dry before storage. The rope should dry naturally, not near a fire or other heat source.

8. To disinfect the rope, you may only use products that have no influence on the synthetic materials used. If you do not comply with these conditions, you put yourself at risk!

9. A rope swells with use and can shrink in length by up to 15%. Regularly check the length of your rope.

10. A wet or icy rope is less abrasion-resistant. It is also harder to control in belay/rappe devices.

11. A knot at the end of the rope is a necessary precaution in a variety of situations (long rappel, poor visibility, fatigue...). Avoid descending too rapidly: risk of burns and accelerated wear of the rope.

12. To make a termination, tie a figure-eight knot at the desired location on the rope. We recommend a figure eight loop for your own rope terminations. There must be at least 10 cm of rope behind the knot. Please tie the knot correctly, as illustrated in Fig.1! Please note the route the load-bearing portion of rope takes (arrow). A different version will reduce the breaking load considerably.

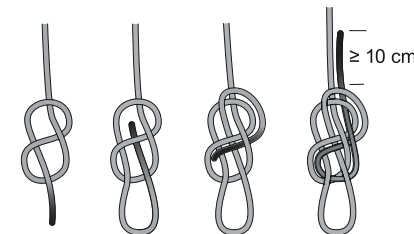

Fig.1 Detail of figure of eight knot

13. If free climbing is necessary when using the rope during rope-supported work, rescuing or speleology, you must use suitable ropes (e.g. dynamic mountaineering ropes in accordance with EN 892).

14. The system must include a reliable anchoring point (in accordance with EN 795, especially 12KN minimum strength) above the user. Avoid slack in any kernmantle rope with limited elongation between the user and the reliable anchoring point.

15. If a rope is cut into several lengths, mark the ends with the correct lengths and end-markings. The new lengths of rope must each be furnished with a copy of the Instructions for Use.

Application:

The rope shall be used in the following applications:

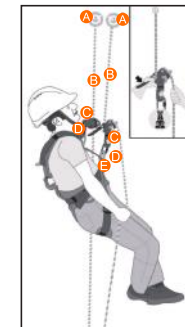

- key
- A. Anchor points (EN 795)
 - B. Ropes (EN 1891)
 - C. Descenders (EN 12841)
 - D. Connector (EN362)
 - E. Full body harness (EN361)

This rope must be used in conjunction with equipment which conform to the European standards (EN361-EN362 - EN795 - EN12841 etc.) and the user need make sure all recommendations of every equipment composing the fall arrest system are understood and applied.

Additional information:

1. This product meets the requirements of Regulation (EU) 2016/425 on personal protective equipment, and IFU (instructions for use) will be attached to the coil/reel.
2. Before the product is used there must be a plan for rescue operations that takes into account

This rope must be used in conjunction with equipment which conform to the European standards (EN361-EN362 - EN795 - EN12841 etc.) and the user need make sure all recommendations of every equipment composing the fall arrest system are understood and applied.

Additional information:

1. This product meets the requirements of Regulation (EU) 2016/425 on personal protective equipment, and IFU (instructions for use) will be attached to the coil/reel.
2. Before the product is used there must be a plan for rescue operations that takes into account all possible emergencies. During and before use, you must consider how to perform the rescue efforts safely and effectively.
3. Do not perform any rope-supported work if your physical condition could compromise your safety during normal use or in an emergency!
4. In a fall arrest system, it is essential to check the required clearance below the user before each use, in order to avoid hitting the ground or an obstacle in case of a fall. Avoid slack in the rope between the user and the anchor point.
5. According to EN 1891, no changes or additions to ropes are permitted and may only be performed by the manufacturer. The breaking load of the rope / rope with terminations applies only to force between one of the end the rope and the other. You should therefore never load a termination loop transversely (2 carabiners in a loop). Check the load on the rope in the selected configuration and never overload it. We recommend a safety factor of ≥ 7 .
6. Make sure that the anchor point is correctly positioned, in order to limit the risk and the length of a fall.
7. A fall arrest harness is the only device allowable for supporting the body in a fall arrest system.
8. The Instructions for Use for each item of equipment used in conjunction with this product must be followed.
9. The Instructions for Use must be provided to the user of this equipment, in the language of the country where the equipment is used. And make sure the markings on the product are legible.

Hoater Guarantee:

This product is guaranteed for 3 years against any faults in materials or manufacture. Exclusions from the guarantee: normal wear and tear, modifications or alterations, incorrect storage, poor maintenance, damage due to accidents, to negligence, or to improper or incorrect usage.



使用说明书

Instructions for use

个人装备：救援、攀登、绳索、器材专业制造商
 Personal equipment: specialist manufacturers of rescue, climbing, ropes and fall protection devices



ENGLISH

Applic to static rope: HT-JL03
Manufacturer: HOATER (Hangzhou) Safety Technology Co., Ltd.
 3507, Xinghui Center, No. 723 Dayuan Road, Lin'an District, Hangzhou City, Zhejiang Province, China
Notified body for EU type examination and production control:
 APAVE SUDEUROPE SAS 8 rue Jean Jacques Vernazza - Z.A.C.Saumaty-Séon - CS 60193 - 13322 MARSEILLE CEDEX 16.

The rope is classed as a personal protective Equipment (PPE) by the European Regulation 2016/425 and has been shown to comply with this Regulation through the European Standard EN1891:1998.

Carefully read these instructions before using this rope

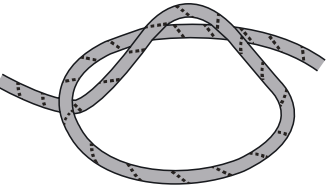

Model:	HT-JL03
Type:	A
Diameter:	12mm
Knotability:	1.0
Sheath slippage:	0.6%
Elongation 50-150kg:	2.6%
Shrinkage:	0%
Weight:	98g/m
The mass of the sheath Sp:	35.9%
The mass of the core C:	64.1%
Min number of falls:	5
Strength:	39.2kN
Min.Tenacity with knots:	15kN
Used material:	Polyamide

- Limitations:**
 Please consider the following application limitations before using this equipment:
- The equipment shall not be used outside its limitations, or for any purpose other than that for which it is intended.
 - The equipment shall only be used by a person trained and competent in its safe use.
 - No more than one personal protective system may be connected at one time.
 - Before use, the supervisors must consider about the risk of possible danger, a rescue plan needs to be established to deal with any emergencies that could arise during the work.
 - During the use, user use equipment must under supervision.
 - Ensure compatibility of all other products used with the equipment when assembled into a system.
 - The user should carry out a pre-use check of the equipment, to ensure that it is in a serviceable condition and operates correctly before it is used.
 - Withdraw the equipment from use if there is any doubt about its condition for safe use or if it has already arrested a fall, do not use it again until confirmed in writing by a competent person.
 - The life span of the product is 10 years but inspection, annually is important to check if any damages have occurred during usage.
 - If it has been subjected to a major fall or load, it must stop use.
 - This equipment is should be treated as a personal issue item.

Field of application:
 This equipment is personal protective equipment—EN1891:1998 type A static rope (low stretch kernmantel rope), and this product is designed to provide protection against the danger of falling from heights. This rope can be used for rope access, working positioning ,travel restraint,as well as rescue,caving or canyoning.It can also be used as a working rope or a safety rope .
 Note: Type A ropes are more suitable for use in rope access and work positioning than

type B ropes.
 If type B ropes are chosen, users should be aware that the level of performance will be less than that of type B; that greater care will be required in protecting against the effects of abrasion, cuts, general wear and tear etc., and than in use gerat care should be taken to minimise the possibility of a fall.

Warning:
 This rope must not be loaded beyond its strength rating,nor be used for any purpose other than that for which it is designed. In particular, don't use them for load lifting.

- Inspection:**
- Your safety is related to the integrity of your equipment.
 - Equipment used for work safety in accordance with EN 365 must be inspected by an expert in close observance of the instructions or by the manufacturer itself at least every 12 months and replaced if necessary.
 - Record the results of the inspection on your PPE inspection form(see form 1): type, model, trade name , identification number, manufacturer contact info , dates: manufacture, purchase, first use, Reason for entry (periodic examination or repair), defects noted, repairs carried out and other relevant information, name and signature of competent person, periodic examination next due date.
 - In general,The inspection must include:
 An inspection of the product' s general condition: age,integrity, soiling proper composition.

- Label inspection: Is the label present? Is the label legible? Is there a CE label? Can you read the Date of MFG?
 Inspection of all individual parts for mechanical damage,e.g.: tears, rips, nicks, abrasion, deformation, ribbing,entangling, crushing.
 Inspection of all individual parts for thermal or chemical damage, e.g.: melting, hardening.
- Before each use visually check the condition of the sheath along the entire length of the rope. Make sure there are no cuts, burns, frayed strands, fuzzy areas, or signs of chemicals.
 - Carry out a tactile inspection of the core along the entire length of the rope,This allows you to detect areas where the core is damaged (hard spot, mushy area).
 - If the equipment has been subject to stress through a fall, it should be withdrawn from use immediately. If you have the slightest doubt, the product must be discarded or may only be used again if an expert has provided written confirmation that it is fit for use after examination.
 - During use: It is important to regularly monitor the condition of the product and its connections to the other equipment in the system. Make sure that all items of equipment are correctly positioned with respect to each other.

- Compatibility:**
- Please ensure that the recommendations for use with other components are maintained: All other components of the working harness must be certified and comply with the relevant standards for PPE
 - Use ropes in accordance with EN 1891 must be used in systems in accordance with EN 341 (Descender Devices for Rescue), EN 358 (work positioning safety belt) or EN 363 (Personal Fall Protection Systems), i.e. for various rope-supported work. Please note that the surface of new, unused ropes can be very smooth and slippery. When using devices, please read the manufacturer' s information on the respective device.
 - Rope devices should be adjusted to the rope diameter.
 - Metal parts must not have any burrs or sharp edges that could damage the rope. Any combination of equipment that affects the safe functioning of any single piece of equipment or the entire system puts you at risk too!

- Precautions for use:**
- Type B ropes have a lower performance level than type A ropes;they are more susceptible to abrasion, cuts, normal wear... It is important to pay greater attention to reducing the potential for falls. Type A ropes are better suited than type B ropes for use in rope access and work positioning.
 - To prolong rope life (better sheath/corecohesion), soak it in water for 24 hours prior to first use. This removes lubricants and otherproducts used in manufacturing. Let the ropedry slowly. It will shrink by approximately 5 %(5 m for every 100 m).
 - Protected from chemicals, heat, abrasion, ultraviolet light, sharp edges that can

- damage your rope.
4. Rubbing together of two ropes through karabiners or maillons induces heat which could result in rupture.
 5. Avoid over-rapid abseiling or lowering which could burn the rope and accelerate sheath wear. The melting temperature of polyamide is 230 C . This temperature may be attained during very rapid descents .
 6. The temperature in which the rope is used must never exceed 80 C .
 7. To clean, rinse the rope with lukewarm water and wipe with a damp cloth. The wet rope should be left to dry before storage. The rope should dry naturally, not near a fire or other heat source.
 8. To disinfect the rope, you may only use products that have no influence on the synthetic materials used. If you do not comply with these conditions, you put yourself at risk!
 9. A rope swells with use and can shrink in length by up to 15 %. Regularly check the length of your rope.
 10. A wet or icy rope is less abrasion-resistant. It is also harder to control in belay/rappel devices.
 11. A knot at the end of the rope is a necessary precaution in a variety of situations (long rappel, poor visibility, fatigue...). Avoid descending too rapidly: risk of burns and accelerated wear of the rope.
 12. To make a termination, tie a figure-eight knot at the desired location on the rope. We recommend a figure eight loop for your own rope terminations. There must be at least 10 cm of rope behind the knot. Please tie the knot correctly, as illustrated in Fig.1! Please note the route the load-bearing portion of rope takes (arrow). A different version will reduce the breaking load considerably.

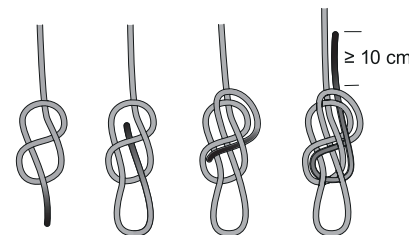
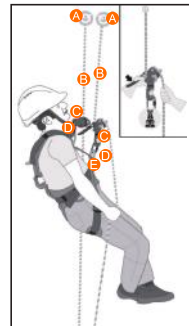

Fig.1 Detail of figure of eight knot

13. If free climbing is necessary when using the rope during rope-supported work, rescuing or speleology, you must use suitable ropes (e.g. dynamic mountaineering ropes in accordance with EN 892).
14. The system must include a reliable anchoring point (in accordance with EN 795,especially 12KN minimum strength) above the user. Avoid slack in any kernmantle rope with limited elongation between the user and the reliable anchoring point.
15. If a rope is cut into several lengths, mark the ends with the correct lengths and end-markings. The new lengths of rope must each be furnished with a copy of the Instructions for Use.

Application:
 The rope shall be used in the following applications:



- key
- A. Anchor points (EN 795)
 - B. Ropes (EN 1891)
 - C. Descenders (EN 12841)
 - D. Connector (EN362)
 - E. Full body harness (EN361)

This rope must be used in conjunction with equipment which conform to the European standards (EN361-EN362 - EN795 - EN12841 etc.) and the user need make sure all recommendations of every equipment composing the fall arrest system are understood and applied.

Additional information:

1. This product meets the requirements of Regulation (EU) 2016/425 on personal protective equipment,and IFU(instructions for use) will be attached to the coil/reel.
2. Before the product is used there must be a plan for rescue operations that takes into account all possible emergencies.During and before use, you must consider how to perform the rescue efforts safely and effectively.
3. Do not perform any rope-supported work if your physical condition could compromise your safety during normal use or in an emergency!
4. In a fall arrest system, it is essential to check the required clearance below the user before each use, in order to avoid hitting the ground or an obstacle in case of a fall. Avoid slack in the rope between the user and the anchor point.
5. According to EN 1891 , no changes or additions to ropes are permitted and may only be performed by the manufacturer.The breaking load of the rope / rope with terminations applies only to force between one of the end of the rope and the other. You should therefore never load a termination loop transversely (2 carabiners in a loop). Check the load on the rope in the selected configuration and never overload it. We recommend a safety factor of ≥ 7 .
6. Make sure that the anchor point is correctly positioned, in order to limit the risk and the length of a fall.
7. A fall arrest harness is the only device allowable for supporting the body in a fall arrest system.
8. The Instructions for Use for each item of equipment used in conjunction with this product must be followed.
9. The Instructions for Use must be provided to the user of this equipment, in the language of the country where the equipment is used. And make sure the markings on the product are legible.

Hoater Guarantee:
 This product is guaranteed for 3 years against any faults in materials or manufacture . Exclusions from the guarantee: normal wear and tear, modifications or alterations, incorrect storage, poor maintenance, damage due to accidents, to negligence, or to improper or incorrect usage.

Declaration of conformity:

Declaration of conformity for rope HT-JL03 available on www.hoater.com

Marking:

Internal marking:
Inside the product, there is a traceability streak, which contains information such as the manufacturer name, it meets standards (EN1891:1998), construction material, type of rope and year of manufacture. This mark is located at least once per meter.

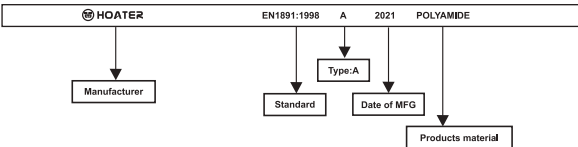

External Marking

Outside the product have a outside marking, which contains information such as product designation, rope type and diameter, it meets standards (EN1891:1998), CE certify, batch number, date of manufacture, trade mark.

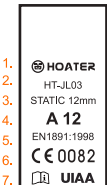

- Brand
- Products model number
- Type and diameter of rope
- The rope standard
- CE standard
- The CE mark showing that the product meets the requirements of the Regulation 2016/425
- Means read instructions is necessity.
- UIAA tag

Storage and transport:

A) When not in use, store the product in a well-ventilated area away from extremes of temperature and to avoid all necessary preventative requirements where environmental or other factors could affect the condition of components, e.g. damp environment, sharp edges, vibration, ultra-violet degradation.
B) For transporting the rope, it should be packed in a bag of suitable size and not together with any sharp edged tools.

Instructions for periodic examination:

It's very important for regular periodic examinations, as the user's safety depends on the continued efficiency and durability of the equipment, at least do it once a year.
The periodic examination also including the requirement to check the legibility of the product marking. The periodic examinations of the ropes are only to be conducted by a competent person for periodic examination and strictly in accordance with the manufacturer's periodic examination procedures.

Instructions for repair:

The product has no repairable features hence the manufacturer does not allow any repair that can be carried out on the product whatsoever.

Check card:

It is recommended that the product be inspected and examined by a competent person for any damages or failures usually if the need arises but at least once a year. The observations should be recorded in the table below. In case such damages are observed, the product should be replaced immediately.

CHINESE

货号: HT-JL03

制造商: 霍安克 (杭州) 安全技术有限公司
中国浙江省杭州市临安区大园路 723 号星汇中心 3507

欧盟型式检验和生产控制认证机构:

APAVE SUDEUROPE SAS
8 rue Jean Jacques Vernazza - Z.A.C.Saumaty-Séon - CS 60193 - 13322 MARSEILLE CEDEX 16.

该绳索被欧洲法规 2016/425 归类为个人防护设备 (PPE), 并已通过欧洲标准 EN1891:1998 证明符合该法规。

在使用此绳索之前, 请仔细阅读这些说明

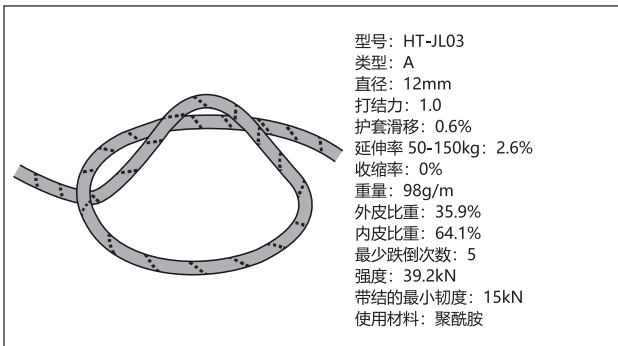

限制:

- 在使用本设备之前, 请考虑以下应用限制:
- 设备不得在其限制范围之外使用, 或用于其预期用途以外的任何目的。
 - 设备只能由经过培训并能够安全使用的人员使用。
 - 一次最多可连接一套个人防护系统。
 - 使用前, 监理人员必须考虑可能发生的危险, 制定救援预案, 以应对工作中可能出现突发事件。
 - 在使用过程中, 用户使用的设备必须在监督下进行。
 - 确保组装到系统中时与设备一起使用的其他产品的兼容性。
 - 用户应对设备进行使用前检查, 确保设备处于可使用状态并正常运行后再使用。
 - 如果对设备的安全使用状况有任何疑问或已经停止跌倒, 请停止使用设备, 直到有资格的人员书面确认后能再次使用。
 - 产品的使用寿命为 10 年, 但每年检查一次很重要, 以检查在使用过程中是否发生任何损坏。
 - 如曾遭受重大跌落或重载, 必须停止使用。
 - 本设备应视为个人物品。

应用领域:

本设备为个人防护设备 --EN1891:1998 A 型静态绳索 (低弹力绳索)。本产品旨在提供防止从高处坠落的危险。该绳索可用于绳索进入、工作定位、旅行约束, 以及救援、探洞或峡谷漂流。也可用作工作绳索或安全绳索。

注意: A 型绳索比 B 型绳索更适合用于绳索进入和工作定位。
如果选择 B 型绳索, 用户应该意识到性能水平会低于 B 型; 需要更加小心地防止磨损、割伤。一般磨损和撕裂等的影响, 并且在使用中应小心谨慎, 以尽量减少跌倒的可能性。

警告

该绳索的负载不得超过其额定强度, 也不得用于其设计用途以外的任何目的。特别是, 不要将它们用于起重。

检查:

- 您的安全与设备的完整性有关。
- 根据 EN 365 用于工作安全的设备必须至少每 12 个月由专家或制造商自行检查一次并严格遵守说明, 并在必要时进行更换。
- 在您的 PPE 检验表上记录检验结果 (见表 1): 类型、型号、商品名称、标识号、制造商联系方式、日期: 制造、购买、首次使用、进入原因 (定期检查或维修)、发现的缺陷、进行的维修和其他相关信息、主管人员的姓名和签名、定期检查下一个到期日。
- 一般, 检查必须包括:
检查产品的一般状况: 年龄、完整性、污染成分。
标签检查: 标签是否存在? 标签是否清晰? 有 CE 标签吗? 你能读懂 MFG 的日期吗? 检查所有单个零件是否有机械损坏, 例如 撕裂、裂口、划痕、磨损、变形、罗纹、缠结、压碎。检查所有单个零件的热损伤或化学损伤, 例如: 熔化、硬化。
- 每次使用前, 目视检查绳索整个长度的护套状况。确保没有割伤、烧伤、磨损的股线、模糊区域或化学品迹象。
- 沿着绳子的整个长度对芯子进行触觉检查, 这样您就可以检测到芯子损坏的区域 (硬点、糊状区域)。
- 如果设备因跌落而受压, 应立即停止使用。如果您有任何疑问, 该产品必须丢弃, 或者只有在专家提供书面确认经检查后适合使用的情况下才能再次使用。
- 使用期间: 定期监测产品的状况及其与系统中其他设备的连接非常重要。确保所有设备项目相对于彼此正确定位。

兼容性:

- 请确保遵守与其他组件一起使用的建议: 工作线束的所有其他组件必须经过认证并符合 PPE 的相关标准
- 使用符合 EN 1891 的绳索必须在符合 EN 341 (救援下降装置)、EN 358 (工作定位安全带) 或 EN 363 (个人坠落保护系统) 的系统上使用, 即用于各种绳索支撑工作。请注意, 新的、未使用过的绳索的表面可能非常光滑和滑。使用设备时, 请阅读相应设备上的制造商信息。
- 绳索装置应根据绳索直径进行调整。
- 金属部件不得有任何可能损坏绳索的毛刺或锋利边缘。任何影响任何单个设备或整个系统安全运行的设备组合也会使您处于危险之中!

使用注意事项

- B 型绳索的性能水平低于 A 型绳索; 它们更容易受到磨损、割伤、正常磨损.....重要的是要更加注意减少跌倒的可能性。A 型绳索比 B 型绳索更适合用于绳索进入和工作定位。
- 为了延长绳索的使用寿命 (更好的外皮 / 芯内聚力), 在首次使用前将其浸泡在水中 24 小时。这可以去除制造过程中使用的润滑剂和其他产品。让绳子慢慢晾干。它将收缩大约 5% (每 100 m 收缩 5 m)。
- 防止化学品、热、磨损、紫外线、可能损坏绳索的锋利边缘。
- 两根绳索通过登山扣或邮包摩擦在一起会产生热量, 从而导致破裂。
- 避免过快的绳索下降或下降, 否则可能会烧毁绳索并加速护套磨损。聚酰胺的熔融温度为 230°C。在非常快速的下降过程中可能会达到这个温度。
- 绳索使用温度不得超过 80°C。
- 要清洁, 用温水中洗绳索, 然后用湿布擦拭。湿绳在存放前应晾干。绳索应自然干燥, 不要靠近火源或其他热源。
- 对绳索进行消毒时, 只能使用对所用合成材料无影响的产品。如果您不遵守这些条件, 您将处于危险之中!
- 绳索随着使用而膨胀, 长度最多可收缩 15%。定期检查绳子的长度。
- 潮湿或结冰的绳索耐磨性较差。在保护 / 绳索设备中也更难控制。
- 在各种情况下 (长绳索、能见度差、疲劳), 绳子末端的结是必要的预防措施。避免下降过快: 有烧伤和加速绳索磨损的风险。
- 要进行终止, 请在绳索的所需位置打一个 8 字形结。我们建议您为自己的绳索端接使用 8 字形环。绳结后面必须有至少 10 厘米的绳索。请正确打结, 如图 1 所示! 请注意绳索的承重部分走的路线 (箭头)。不同的版本将大大降低断裂载荷。



图1 八结图细节

- 如果在绳索支撑工作、救援或洞穴穴中使用绳索时需要自由攀登, 则必须使用合适的绳索 (例如, 符合 EN 892 的动态登山绳索)。
- 系统必须在用户上方包括一个可靠的锚固点 (根据 EN 795, 尤其是 12KN 最小强度)。避免在用户和可靠锚固点之间伸长有限的任何 kernmantle 绳索松弛。
- 如果绳子被切成几段, 用正确的长度和末端标记标记末端。每根新的绳索都必须附有使用说明的副本。

应用

绳索应用于以下用途:

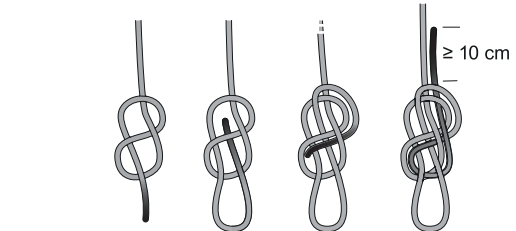
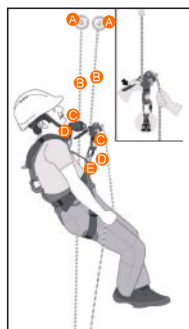

关键点

- 锚点 (EN 795)
- 绳索 (EN 1891)
- 下降器 (EN 12841)
- 连接器 (EN362)
- 全身安全带 (EN361)

该绳索必须与符合欧洲标准 (EN361-EN362 - EN795 - EN12841 等) 的设备一起使用, 并且用户需要确保了解和应用构成防坠落系统的每个设备的所有建议。

附加信息

- 本产品符合欧盟法规 (EU) 2016/425 对个人防护设备的要求, 并在线圈 / 卷盘上附有 IFU (使用说明)。
- 在使用产品之前, 必须有一个考虑到所有可能的紧急情况的救援行动计划。在使用过程中和使用之前, 您必须考虑如何安全有效地进行救援工作。
- 如果您的身体状况在正常使用或紧急情况下可能危及您的安全, 请勿进行任何绳索支撑工作!
- 在防坠落系统中, 每次使用前必须检查用户下方所需的间隙, 以免坠落时撞到地面或障碍物。避免用户和锚点之间的绳索松弛。
- 根据 EN 1891, 不允许对绳索进行更改或添加, 并且只能由制造商执行。绳索 / 带末端的绳索的断裂载荷仅适用于绳索一端与另一端之间的力。因此, 您不应该横向加载终端环 (一个环中有 2 个登山扣)。检查所选配置中绳索上的负载, 切勿使其过载。我们建议安全系数 ≥ 7 。
- 确保锚点位置正确, 以限制跌倒的风险和长度。
- 防坠落安全带是唯一允许在防坠落系统中支撑身体的装置。
- 必须遵守与本产品一起使用的每项设备的使用说明。
- 必须以使用设备所在国家 / 地区的语言向本设备的用户提供使用说明。并确保产品上的标记清晰易读。

HOATER 保证

本产品质保 3 年, 不会出现任何材料或制造缺陷。保修范围不包括: 正常磨损、修改或更改、不正确的存储、维护不善、由于事故、疏忽或不正确或不正确的使用造成的损坏。

符合性声明

www.hoater.com 上提供绳索 HT-JL03 的符合性声明

标记

内部标记:

产品内部有一条可追溯性条纹, 其中包含制造商名称、符合标准 (EN1891:1998)、结构材料、绳索类型和制造年份等信息。此标记每米至少出现一次。

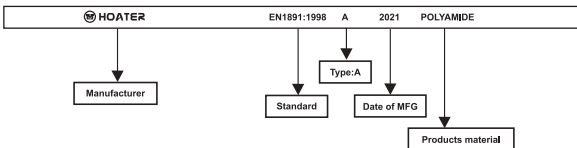

外部标记

产品外部有一个外部标记, 包含产品名称、绳索类型和直径等信息, 符合标准 (EN1891:1998)、CE 认证、批号、生产日期、商标。

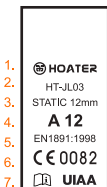

- 品牌
- 产品型号
- 绳索的种类和直径
- 绳子的标准
- CE 标准
- CE 标志表明产品符合法规 2016/425 的要求
- 意味着阅读说明是必要的。
- UIAA 标记

储存和运输

- 不使用时, 将产品存放在通风良好的地方, 远离极端温度, 并避免环境或其他因素可能影响组件状况的所有必要预防要求, 例如潮湿环境、锋利边缘、振动、紫外线降解。
- 运输绳索时, 应装在大小合适的袋子中, 不要与任何锋利的工具一起运输。

定期检查说明:

定期检查非常重要, 因为用户的安全取决于设备的持续效率和耐用性, 至少每年进行一次。定期检查还包括要求检查产品标记的易读性。钢丝绳的定期检查只能由合格的定期检查人员进行, 并严格按照制造商的定期检查程序进行。

维修说明:

该产品没有可修复的功能, 因此制造商不允许对产品进行任何维修。

检查卡

建议通常在需要时由合格人员检查和检查产品是否有任何损坏或故障, 但至少每年一次。观察结果应记录在下表中。如果发现此类损坏, 应立即更换产品。

识别及保修证书 Identification and warranty certificate			
产品类型: Product type			
产品型号: Product number			
制造年份: Year of manufacture			
购买日期: Purchase date			
购买自: Purchased from			
首次使用日期: Date of first use			
监管者: Regulators			
使用者: User:			
公司机构: Company			
注释: Comments			
本文件附属于本产品或使用系统 This documentation should be issued with and kept for each item or system			

定期检查 / 每 3 个月例行检查 Regular inspection/routine inspection every 3 months			
日期 Date	结果 Decision	检查者 Inspector	下次检查日期 Next inspecting
本文件附属于本产品或使用系统 This documentation should be issued with and kept for each item or system			



使用说明书

Instructions for use

个人装备：救援、攀登、绳索、器材专业制造商
 Personal equipment: specialist manufacturers of rescue, climbing, ropes and fall protection devices



ENGLISH

Applic to static rope: HT-JL011
Manufacturer: HOATER (Hangzhou) Safety Technology Co., Ltd.
 3507, Xinghui Center, No. 723 Dayuan Road, Lin'an District, Hangzhou City, Zhejiang Province, China
Notified body for EU type examination and production control:
 APAVE SUDEUROPE SAS 8 rue Jean Jacques Vernazza - Z.A.C.Saumaty-Séon - CS 60193 - 13322 MARSEILLE CEDEX 16.

The rope is classed as a personal protective Equipment (PPE) by the European Regulation 2016/425 and has been shown to comply with this Regulation through the European Standard EN1891:1998.

Carefully read these instructions before using this rope

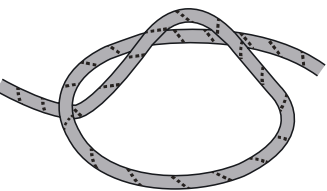

Model:	HT-JL011
Type:	B
Diameter:	9mm
Knotability:	1.1
Sheath slippage:	0.3%
Elongation 50-150kg:	2.8%
Shrinkage:	1.7%
Weight:	54g/m
The mass of the sheath Sp:	40.1%
The mass of the core C:	59.9%
Min number of falls:	5
Impact Force:	24 kN
Static strength with terminations:	12 kN during 3 minutes
Fall arrest peak force:	4.7kN
Used material:	Polyamide

- Limitations:**
 Please consider the following application limitations before using this equipment:
- The equipment shall not be used outside its limitations, or for any purpose other than that for which it is intended.
 - The equipment shall only be used by a person trained and competent in its safe use.
 - No more than one personal protective system may be connected at one time.
 - Before use, the supervisors must consider about the risk of possible danger, a rescue plan needs to be established to deal with any emergencies that could arise during the work.
 - During the use, user use equipment must under supervision.
 - Ensure compatibility of all other products used with the equipment when assembled into a system.
 - The user should carry out a pre-use check of the equipment, to ensure that it is in a serviceable condition and operates correctly before it is used.
 - Withdraw the equipment from use if there is any doubt about its condition for safe use or if it has already arrested a fall, do not use it again until confirmed in writing by a competent person.
 - The life span of the product is 10 years but inspection, annually is important to check if any damages have occurred during usage.
 - If it has been subjected to a major fall or load, it must stop use.
 - This equipment is should be treated as a personal issue item.

Field of application:
 This equipment is personal protective equipment—EN1891:1998 type A static rope (low stretch kernmantel rope), and this product is designed to provide protection against the danger of falling from heights. This rope can be used for rope access, working positioning, travel restraint, as well as rescue, caving or canyoning. It can also be used as a working rope or a safety rope.
 Note: Type A ropes are more suitable for use in rope access and work positioning than

type B ropes.
 If type B ropes are chosen, users should be aware that the level of performance will be less than that of type B; that greater care will be required in protecting against the effects of abrasion, cuts, general wear and tear etc., and than in use great care should be taken to minimise the possibility of a fall.

Warning:
 This rope must not be loaded beyond its strength rating, nor be used for any purpose other than that for which it is designed. In particular, don't use them for load lifting.

Inspection:
 1. Your safety is related to the integrity of your equipment.
 2. Equipment used for work safety in accordance with EN 365 must be inspected by an expert in close observance of the instructions or by the manufacturer itself at least every 12 months and replaced if necessary.
 3. Record the results of the inspection on your PPE inspection form (see form 1): type, model, trade name, identification number, manufacturer contact info, dates: manufacture, purchase, first use, Reason for entry (periodic examination or repair), defects noted, repairs carried out and other relevant information, name and signature of competent person, periodic examination next due date.
 4. IN general, The inspection must include:
 An inspection of the product's general condition: age, integrity, soiling proper composition.
 Label inspection: Is the label present? Is the label legible? Is there a CE label? Can you read the Date of MFG?
 Inspection of all individual parts for mechanical damage, e.g.: tears, rips, nicks, abrasion, deformation, ribbing, entangling, crushing.
 Inspection of all individual parts for thermal or chemical damage, e.g.: melting, hardening.
 5. Before each use visually check the condition of the sheath along the entire length of the rope. This allows you to detect areas where the core is damaged (hard spot, mushy area).
 6. Carry out a tactile inspection of the core along the entire length of the rope. This allows you to detect areas where the core is damaged (hard spot, mushy area).
 7. If the equipment has been subject to stress through a fall, it should be withdrawn from use immediately. If you have the slightest doubt, the product must be discarded or may only be used again if an expert has provided written confirmation that it is fit for use after examination.
 8. During use: It is important to regularly monitor the condition of the product and its connections to the other equipment in the system. Make sure that all items of equipment are correctly positioned with respect to each other.

Compatibility:
 1. Please ensure that the recommendations for use with other components are maintained: All other components of the working harness must be certified and comply with the relevant standards for PPE
 2. Use ropes in accordance with EN 1891 must be used in systems in accordance with EN 341 (Descender Devices for Rescue), EN 358 (work positioning safety belt) or EN 363 (Personal Fall Protection Systems), i.e. for various rope-supported work. Please note that the surface of new, unused ropes can be very smooth and slippery. When using devices, please read the manufacturer's information on the respective device.
 3. Rope devices should be adjusted to the rope diameter.
 4. Metal parts must not have any burrs or sharp edges that could damage the rope.
 Any combination of equipment that affects the safe functioning of any single piece of equipment or the entire system puts you at risk too!

Precautions for use:
 1. Type B ropes have a lower performance level than type A ropes; they are more susceptible to abrasion, cuts, normal wear... It is important to pay greater attention to reducing the potential for falls. Type A ropes are better suited than type B ropes for use in rope access and work positioning.
 2. To prolong rope life (better sheath/core cohesion), soak it in water for 24 hours prior to first use. This removes lubricants and other products used in manufacturing. Let the rope dry slowly. It will shrink by approximately 5% (5 m for every 100 m).
 3. Protected from chemicals, heat, abrasion, ultraviolet light, sharp edges that can

damage your rope.
 4. Rubbing together of two ropes through karabiners or maillons induces heat which could result in rupture.
 5. Avoid over-rapid abseiling or lowering which could burn the rope and accelerate sheath wear. The melting temperature of polyamide is 230 °C. This temperature may be attained during very rapid descents.
 6. The temperature in which the rope is used must never exceed 80 °C.
 7. To clean, rinse the rope with lukewarm water and wipe with a damp cloth. The wet rope should be left to dry before storage. The rope should dry naturally, not near a fire or other heat source.
 8. To disinfect the rope, you may only use products that have no influence on the synthetic materials used. If you do not comply with these conditions, you put yourself at risk!
 9. A rope swells with use and can shrink in length by up to 15%. Regularly check the length of your rope.
 10. A wet or icy rope is less abrasion-resistant. It is also harder to control in belay/rappel devices.
 11. A knot at the end of the rope is a necessary precaution in a variety of situations (long rappel, poor visibility, fatigue...). Avoid descending too rapidly: risk of burns and accelerated wear of the rope.
 12. To make a termination, tie a figure-eight knot at the desired location on the rope. We recommend a figure eight loop for your own rope terminations. There must be at least 10 cm of rope behind the knot. Please tie the knot correctly, as illustrated in Fig.1! Please note the route the load-bearing portion of rope takes (arrow). A different version will reduce the breaking load considerably.

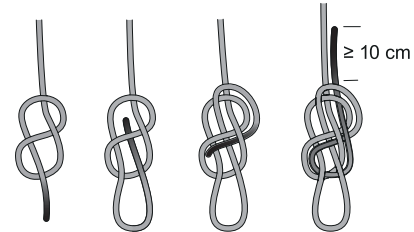
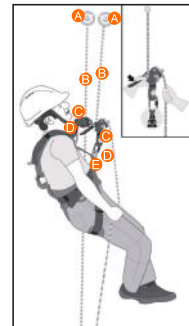

Fig.1 Detail of figure of eight knot

13. If free climbing is necessary when using the rope during rope-supported work, rescuing or speleology, you must use suitable ropes (e.g. dynamic mountaineering ropes in accordance with EN 892).
 14. The system must include a reliable anchoring point (in accordance with EN 795, especially 12kN minimum strength) above the user. Avoid slack in any kernmantle rope with limited elongation between the user and the reliable anchoring point.
 15. If a rope is cut into several lengths, mark the ends with the correct lengths and end-markings. The new lengths of rope must each be furnished with a copy of the Instructions for Use.

Application:
 The rope shall be used in the following applications:



- key
 A. Anchor points (EN 795)
 B. Ropes (EN 1891)
 C. Descenders (EN 12841)
 D. Connector (EN362)
 E. Full body harness (EN361)

This rope must be used in conjunction with equipment which conform to the European standards (EN361-EN362 - EN795 - EN12841 etc.) and the user need make sure all recommendations of every equipment composing the fall arrest system are understood and applied.

Additional information:
 1. This product meets the requirements of Regulation (EU) 2016/425 on personal protective equipment, and IFU (instructions for use) will be attached to the coil/reel.
 2. Before the product is used there must be a plan for rescue operations that takes into account
 This rope must be used in conjunction with equipment which conform to the European standards (EN361-EN362 - EN795 - EN12841 etc.) and the user need make sure all recommendations of every equipment composing the fall arrest system are understood and applied.

Additional information:
 1. This product meets the requirements of Regulation (EU) 2016/425 on personal protective equipment, and IFU (instructions for use) will be attached to the coil/reel.
 2. Before the product is used there must be a plan for rescue operations that takes into account all possible emergencies. During and before use, you must consider how to perform the rescue efforts safely and effectively.
 3. Do not perform any rope-supported work if your physical condition could compromise your safety during normal use or in an emergency!
 4. In a fall arrest system, it is essential to check the required clearance below the user before each use, in order to avoid hitting the ground or an obstacle in case of a fall. Avoid slack in the rope between the user and the anchor point.
 5. According to EN 1891, no changes or additions to ropes are permitted and may only be performed by the manufacturer. The breaking load of the rope / rope with terminations applies only to force between one of the end the rope and the other. You should therefore never load a termination loop transversely (2 carabiners in a loop). Check the load on the rope in the selected configuration and never overload it. We recommend a safety factor of ≥ 7 .
 6. Make sure that the anchor point is correctly positioned, in order to limit the risk and the length of a fall.
 7. A fall arrest harness is the only device allowable for supporting the body in a fall arrest system.
 8. The Instructions for Use for each item of equipment used in conjunction with this product must be followed.
 9. The Instructions for Use must be provided to the user of this equipment, in the language of the country where the equipment is used. And make sure the markings on the product are legible.

Hoater Guarantee:
 This product is guaranteed for 3 years against any faults in materials or manufacture. Exclusions from the guarantee: normal wear and tear, modifications or alterations, incorrect storage, poor maintenance, damage due to accidents, to negligence, or to improper or incorrect usage.

Declaration of conformity:

Declaration of conformity for rope HT-JL011 available on www.hoater.com

Marking:

Internal marking:
Inside the product, there is a traceability streak, which contains information such as the manufacturer name, it meets standards (EN1891:1998), construction material, type of rope and year of manufacture. This mark is located at least once per meter.

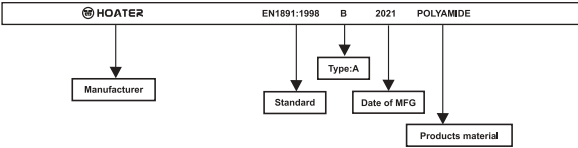

External Marking

Outside the product have a outside marking, which contains information such as product designation, rope type and diameter, it meets standards (EN1891:1998), CE certify, batch number, date of manufacture, trade mark.

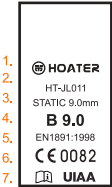

- 1.Brand 2.Products model number 3.Type and diameter of rope 4.The rope standard 5.CE standard 6.The CE mark showing that the product meets the requirements of the Regulation 2016/425 7.Means read instructions is necessity. 8.UIAA tag

Storage and transport:

A) When not in use, store the product in a well-ventilated area away from extremes of temperature and to avoid all necessary preventative requirements where environmental or other factors could affect the condition of components, e.g. damp environment, sharp edges, vibration, ultra-violet degradation. B) For transporting the rope, it should be packed in a bag of suitable size and not together with any sharp edged tools.

Instructions for periodic examination:

It's very important for regular periodic examinations, as the user's safety depends on the continued efficiency and durability of the equipment, at least do it once a year. The periodic examination also including the requirement to check the legibility of the product marking. The periodic examinations of the ropes are only to be conducted by a competent person for periodic examination and strictly in accordance with the manufacturer's periodic examination procedures.

Instructions for repair:

The product has no repairable features hence the manufacturer does not allow any repair that can be carried out on the product whatsoever.

Check card:

It is recommended that the product be inspected and examined by a competent person for any damages or failures usually if the need arises but at least once a year. The observations should be recorded in the table below. In case such damages are observed, the product should be replaced immediately.

CHINESE

货号: HT-JL011

制造商: 霍安克 (杭州) 安全技术有限公司
中国浙江省杭州市临安区大园路 723 号星汇中心 3507

欧盟型式检验和生产控制认证机构:
APAVE SUDEUROPE SAS
8 rue Jean Jacques Vernazza - Z.A.C.Saumaty-Séon - CS 60193 - 13322 MARSEILLE CEDEX 16.

该绳索被欧洲法规 2016/425 归类为个人防护设备 (PPE), 并已通过欧洲标准 EN1891:1998 证明符合该法规。

在使用此绳索之前, 请仔细阅读这些说明

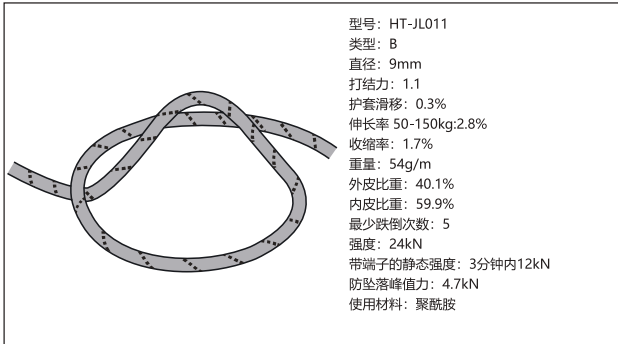

限制:

在使用本设备之前, 请考虑以下应用限制:

- 1. 设备不得在其限制范围之外使用, 或用于其预期用途以外的任何目的。 2. 设备只能由经过培训并能够安全使用的人员使用。 3. 一次最多可连接一套个人防护系统。 4. 使用前, 监理人员必须考虑可能发生的危险, 制定救援预案, 以应对工作中可能出现过的突发事件。 5. 在使用过程中, 用户使用的设备必须在监督下进行。 6. 确保组装到系统中时与设备一起使用的其他产品的兼容性。 7. 用户应对设备进行使用前检查, 确保设备处于可使用状态并正常运行后再使用。 8. 如果对设备的安全使用状况有任何疑问或已经停止跌倒, 请停止使用设备, 直到有资格的人员书面确认后才能再次使用。 9. 产品的使用寿命为 10 年, 但每年检查一次很重要, 以检查在使用过程中是否发生任何损坏。 10. 如曾遭受重大跌落或重载, 必须停止使用。 11. 本设备应视为个人物品。

应用领域:

本设备为个人防护设备 --EN1891:1998 A 型静态绳索 (低弹力绳索)。本产品旨在提供防止从高处坠落的风险。该绳索可用于绳索进入、工作定位、旅行约束, 以及救援、探洞或峡谷漂流。也可用作工作绳索或安全绳索。

注意: A 型绳索比 B 型绳索更适合用于绳索进入和工作定位。 如果选择 B 型绳索, 用户应该意识到性能水平会低于 B 型; 需要更加小心地防止磨损、割伤。一般磨损和撕裂等的影响, 并且在使用中应小心谨慎, 以尽量减少跌倒的可能性。

警告

该绳索的负载不得超过其额定强度, 也不得用于其设计用途以外的任何目的。特别是, 不要将它们用于起重。

检查:

- 1. 您的安全与设备的完整性有关。 2. 根据 EN 365 用于工作安全的设备必须至少每 12 个月由专家或制造商自行检查一次并严格遵守说明, 并在必要时进行更换。 3. 在您的 PPE 检验表上记录检验结果 (见表 1): 类型、型号、商品名称、标识号、制造商联系方式、日期: 制造、购买、首次使用、进入原因 (定期检查或维修)、发现的缺陷、进行的维修和其他相关信息、主管人员的姓名和签名、定期检查下一个到期日。 4. 一般, 检查必须包括: 检查产品的一般状况: 年龄、完整性、污染成分。 标签检查: 标签是否存在? 标签是否清晰? 有 CE 标签吗? 你能读懂 MFG 的日期吗? 检查所有单个零件是否有机械损坏, 例如: 撕裂、裂口、划痕、磨损、变形、罗纹、缠结、压碎。 检查所有单个零件的热损伤或化学损伤, 例如: 熔化、硬化。 5. 每次使用前, 目视检查绳索整个长度的护套状况。确保没有割伤、烧伤、磨损的股线、模糊区域或化学品迹象。 6. 沿着绳子的整个长度对芯子进行触觉检查, 这样您就可以检测到芯子损坏的区域 (硬点、糊状区域)。 7. 如果设备因跌落而受压, 应立即停止使用。如果您有任何疑问, 该产品必须丢弃, 或者只有在专家提供书面确认经检查后适合使用的情况下才能再次使用。 8. 使用期间: 定期监测产品的状况及其与系统中其他设备的连接非常重要。确保所有设备项目相对于彼此正确定位。

兼容性:

- 1. 请确保遵守与其他组件一起使用的建议: 工作线束的所有其他组件必须经过认证并符合 PPE 的相关标准 2. 使用符合 EN 1891 的绳索必须在符合 EN 341 (救援下降装置)、EN 358 (工作定位安全带) 或 EN 363 (个人坠落保护系统) 的系统中使用, 即用于各种绳索支撑工作。请注意, 新的、未使用过的绳索的表面可能非常光滑和滑。使用设备时, 请阅读相应设备上的制造商信息。 3. 绳索装置应根据绳索直径进行调整。 4. 金属部件不得有任何可能损坏绳索的毛刺或锋利边缘。任何影响任何单个设备或整个系统安全运行的设备组合也会使您处于危险之中!

使用注意事项

- 1. B 型绳索的性能水平低于 A 型绳索; 它们更容易受到磨损、割伤、正常磨损.....重要的是要更加注意减少跌倒的可能性。A 型绳索比 B 型绳索更适合用于绳索进入和工作定位。 2. 为了延长绳索的使用寿命 (更好的外皮 / 芯内聚力), 在首次使用前将其浸泡在水中 24 小时, 这可以去除制造过程中使用的润滑剂和其他产品。让绳子慢慢晾干。它将收缩大约 5% (每 100 m 收缩 5 m)。 3. 防止化学品、热、磨损、紫外线、可能损坏绳索的锋利边缘。 4. 两根绳索通过登山扣或邮包摩擦在一起会产生热量, 从而导致破裂。 5. 避免过快的绳索下降或下降, 否则可能会烧毁绳索并加速护套磨损。聚酰胺的熔融温度为 230°C。在非常快速的下降过程中可能会达到这个温度。 6. 绳索使用温度不得超过 80°C。 7. 要清洁, 用温水冲洗绳索, 然后用湿布擦拭。湿绳在存放前应晾干。绳索应自然干燥, 不要靠近火源或其他热源。 8. 对绳索进行消毒时, 只能使用对所用合成材料无影响的产品。如果您不遵守这些条件, 您将处于危险之中! 9. 绳索随着使用而膨胀, 长度最多可收缩 15%。定期检查绳子的长度。 10. 潮湿或结冰的绳索耐磨性较差。在保护 / 绳索设备中也更难控制。 11. 在各种情况下 (长绳索、能见度差、疲劳), 绳子末端的结是必要的预防措施。避免下降过快: 有烧伤和加速绳索磨损的风险。 12. 要进行终止, 请在绳索的所需位置打一个 8 字形结。我们建议您为自己的绳索端接使用 8 字形环。绳结后面必须有至少 10 厘米的绳索。请正确打结, 如图 1 所示! 请注意绳索的承重部分走的路线 (箭头)。不同的版本将大大降低断裂载荷。



图1 八结图细节

- 13. 如果在绳索支撑工作、救援或洞穴穴中使用绳索时需要自由攀登, 则必须使用合适的绳索 (例如, 符合 EN 892 的动态登山绳索)。 14. 系统必须在用户上方包括一个可靠的锚固点 (根据 EN 795, 尤其是 12KN 最小强度)。避免在用户和可靠锚固点之间伸长有限的任何 kernmantle 绳索松弛。 15. 如果绳子被切成几段, 用正确的长度和末端标记标记末端。每根新的绳索都必须附有使用说明的副本。

应用

绳索应用于以下用途:

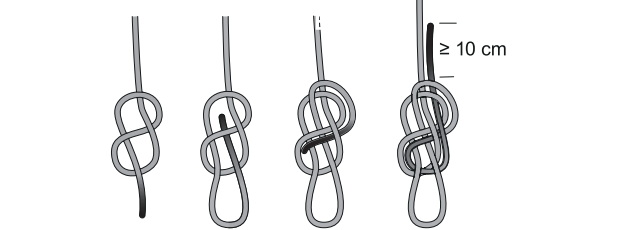
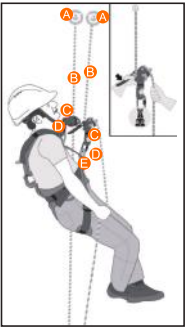

关键点

- A. 锚点 (EN 795) B. 绳索 (EN 1891) C. 下降器 (EN 12841) D. 连接器 (EN362) E. 全身安全带 (EN361)

该绳索必须与符合欧洲标准 (EN361-EN362 - EN795 - EN12841 等) 的设备一起使用, 并且用户需要确保了解和应用构成防坠落系统的每个设备的所有建议。

附加信息

- 1. 本产品符合欧盟法规 (EU) 2016/425 对个人防护设备的要求, 并在线圈 / 卷盘上附有 IFU (使用说明)。 2. 在使用产品之前, 必须有一个考虑到所有可能的紧急情况救援行动计划。在使用过程中和使用之前, 您必须考虑如何安全有效地进行救援工作。 3. 如果您的身体状况在正常使用或紧急情况下可能危及您的安全, 请勿进行任何绳索支撑工作! 4. 在防坠落系统中, 每次使用前必须检查用户下方所需的间隙, 以免坠落时撞到地面或障碍物。避免用户和锚点之间的绳索松弛。 5. 根据 EN 1891, 不允许对绳索进行更改或添加, 并且只能由制造商执行。绳索 / 带末端的绳索的断裂载荷仅适用于绳索一端与另一端之间的力。因此, 您不应该横向加载终端环 (一个环中有 2 个登山扣)。检查所选配置中绳索上的负载, 切勿使其过载。我们建议安全系数 ≥ 7。 6. 确保锚点位置正确, 以限制跌倒的风险和长度。 7. 防坠落安全带是唯一允许在防坠落系统中支撑身体的装置。 8. 必须遵守与本产品一起使用的每项设备的使用说明。 9. 必须以使用设备所在国家 / 地区的语言向本设备的用户提供使用说明。并确保产品上的标记清晰易读。

HOATER 保证

本产品质保 3 年, 不会出现任何材料或制造缺陷。保修范围不包括: 正常磨损、修改或更改、不正确的存储、维护不善、由于事故、疏忽或不正确或不正确的使用造成的损坏。

符合性声明

www.hoater.com 上提供绳索 HT-JL011 的符合性声明

标记

内部标记:
产品内部有一条可追溯性条纹, 其中包含制造商名称、符合标准 (EN1891:1998)、结构材料、绳索类型和制造年份等信息。此标记每米至少出现一次。

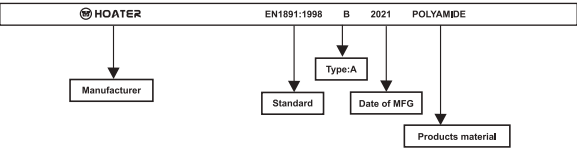

外部标记

产品外部有一个外部标记, 包含产品名称、绳索类型和直径等信息, 符合标准 (EN1891:1998)、CE 认证、批号、生产日期、商标。

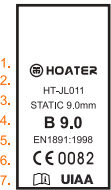

- 1.品牌 2.产品型号 3.绳索的种类和直径 4.绳子的标准 5.CE标准 6.CE标志表明产品符合法规2016/425的要求 7.意味着阅读说明是必要的。 8.UIAA标记

储存和运输

- A) 不使用时, 将产品存放在通风良好的地方, 远离极端温度, 并避免环境或其他因素可能影响组件状况的所有必要预防要求, 例如潮湿环境、锋利边缘、振动、紫外线降解。 B) 运输绳索时, 应装在大小合适的袋子中, 不要与任何锋利的工具一起运输。

定期检查说明:

定期检查非常重要, 因为用户的安全取决于设备的持续效率和耐用性, 至少每年进行一次。定期检查还包括要求检查产品标记的易读性。钢丝绳的定期检查只能由合格的定期检查人员进行, 并严格按照制造商的定期检查程序进行。

维修说明:

该产品没有可修复的功能, 因此制造商不允许对产品进行任何维修。

检查卡

建议通常在需要时由合格人员检查和检查产品是否有任何损坏或故障, 但至少每年一次。观察结果应记录在下表中。如果发现此类损坏, 应立即更换产品。

识别及保修证书 Identification and warranty certificate			
产品类型: Product type			
产品型号: Product number			
制造年份: Year of manufacture			
购买日期: Purchase date			
购买自: Purchased from			
首次使用日期: Date of first use			
监管者: Regulators			
使用者: User:			
公司机构: Company			
注释: Comments			
本文件附属于本产品或使用系统 This documentation should be issued with and kept for each item or system			

定期检查 / 每 3 个月例行检查 Regular inspection/routine inspection every 3 months			
日期 Date	结果 Decision	检查者 Inspector	下次检查日期 Next inspecting
本文件附属于本产品或使用系统 This documentation should be issued with and kept for each item or system			



使用说明书

Instructions for use

个人装备：救援、攀登、绳索、器材专业制造商
 Personal equipment: specialist manufacturers of rescue, climbing, ropes and fall protection devices



ENGLISH

Applic to static rope: HT-JL012
Manufacturer: HOATER (Hangzhou) Safety Technology Co., Ltd.
 3507, Xinghui Center, No. 723 Dayuan Road, Lin'an District, Hangzhou City, Zhejiang Province, China
Notified body for EU type examination and production control:
 APAVE SUDEUROPE SAS 8 rue Jean Jacques Vernazza - Z.A.C.Saumaty-Séon - CS 60193 - 13322 MARSEILLE CEDEX 16.

The rope is classed as a personal protective Equipment (PPE) by the European Regulation 2016/425 and has been shown to comply with this Regulation through the European Standard EN1891:1998.

Carefully read these instructions before using this rope

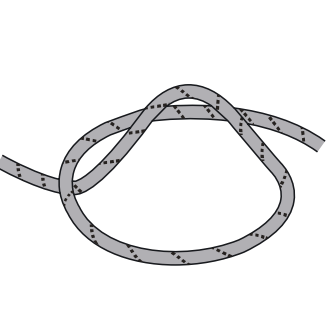

Model:	HT-JL012
Type:	A
Diameter:	10mm
Knotability:	1.1
Sheath slippage:	0.1%
Elongation 50-150kg:	2.5%
Shrinkage:	1.6%
Weight:	65.7g/m
The mass of the sheath Sp:	40.5%
The mass of the core C:	49.5%
Min number of falls:	5
Static strength without terminations:	28.7kN
Static strength with terminations:	15 kN during 3 minutes
Fall arrest peak force :	5.5kN
Used material:	Polyamide

- Limitations:**
 Please consider the following application limitations before using this equipment:
- The equipment shall not be used outside its limitations, or for any purpose other than that for which it is intended.
 - The equipment shall only be used by a person trained and competent in its safe use.
 - No more than one personal protective system may be connected at one time.
 - Before use, the supervisors must consider about the risk of possible danger, a rescue plan needs to be established to deal with any emergencies that could arise during the work.
 - During the use, user use equipment must under supervision.
 - Ensure compatibility of all other products used with the equipment when assembled into a system.
 - The user should carry out a pre-use check of the equipment, to ensure that it is in a serviceable condition and operates correctly before it is used.
 - Withdraw the equipment from use if there is any doubt about its condition for safe use or if it has already arrested a fall, do not use it again until confirmed in writing by a competent person.
 - The life span of the product is 10 years but inspection, annually is important to check if any damages have occurred during usage.
 - If it has been subjected to a major fall or load, it must stop use.
 - This equipment is should be treated as a personal issue item.

Field of application:
 This equipment is personal protective equipment—EN1891:1998 type A static rope (low stretch kernmantel rope), and this product is designed to provide protection against the danger of falling from heights. This rope can be used for rope access, working positioning, travel restraint, as well as rescue, caving or canyoning. It can also be used as a working rope or a safety rope.
 Note: Type A ropes are more suitable for use in rope access and work positioning than

type B ropes.
 If type B ropes are chosen, users should be aware that the level of performance will be less than that of type B; that greater care will be required in protecting against the effects of abrasion, cuts, general wear and tear etc., and than in use great care should be taken to minimise the possibility of a fall.

Warning:
 This rope must not be loaded beyond its strength rating, nor be used for any purpose other than that for which it is designed. In particular, don't use them for load lifting.

Inspection:
 1. Your safety is related to the integrity of your equipment.
 2. Equipment used for work safety in accordance with EN 365 must be inspected by an expert in close observance of the instructions or by the manufacturer itself at least every 12 months and replaced if necessary.
 3. Record the results of the inspection on your PPE inspection form (see form 1): type, model, trade name, identification number, manufacturer contact info, dates: manufacture, purchase, first use, Reason for entry (periodic examination or repair), defects noted, repairs carried out and other relevant information, name and signature of competent person, periodic examination next due date.
 4. In general, The inspection must include:
 An inspection of the product's general condition: age, integrity, soiling proper composition.
 Label inspection: Is the label present? Is the label legible? Is there a CE label? Can you read the Date of MFG?
 Inspection of all individual parts for mechanical damage, e.g.: tears, rips, nicks, abrasion, deformation, ribbing, entangling, crushing.
 Inspection of all individual parts for thermal or chemical damage, e.g.: melting, hardening.

- Before each use visually check the condition of the sheath along the entire length of the rope. This allows you to detect areas where the core is damaged (hard spot, mushy area).
- If the equipment has been subject to stress through a fall, it should be withdrawn from use immediately. If you have the slightest doubt, the product must be discarded or may only be used again if an expert has provided written confirmation that it is fit for use after examination.
- During use: It is important to regularly monitor the condition of the product and its connections to the other equipment in the system. Make sure that all items of equipment are correctly positioned with respect to each other.

Compatibility:
 1. Please ensure that the recommendations for use with other components are maintained: All other components of the working harness must be certified and comply with the relevant standards for PPE
 2. Use ropes in accordance with EN 1891 must be used in systems in accordance with EN 341 (Descender Devices for Rescue), EN 358 (work positioning safety belt) or EN 363 (Personal Fall Protection Systems), i.e. for various rope-supported work. Please note that the surface of new, unused ropes can be very smooth and slippery. When using devices, please read the manufacturer's information on the respective device.
 3. Rope devices should be adjusted to the rope diameter.
 4. Metal parts must not have any burrs or sharp edges that could damage the rope. Any combination of equipment that affects the safe functioning of any single piece of equipment or the entire system puts you at risk too!

Precautions for use:
 1. Type B ropes have a lower performance level than type A ropes; they are more susceptible to abrasion, cuts, normal wear... It is important to pay greater attention to reducing the potential for falls. Type A ropes are better suited than type B ropes for use in rope access and work positioning.
 2. To prolong rope life (better sheath/core cohesion), soak it in water for 24 hours prior to first use. This removes lubricants and other products used in manufacturing. Let the rope dry slowly. It will shrink by approximately 5% (5 m for every 100 m).
 3. Protected from chemicals, heat, abrasion, ultraviolet light, sharp edges that can

- damage your rope.
- Rubbing together of two ropes through karabiners or maillons induces heat which could result in rupture.
 - Avoid over-rapid abseiling or lowering which could burn the rope and accelerate sheath wear. The melting temperature of polyamide is 230 °C. This temperature may be attained during very rapid descents.
 - The temperature in which the rope is used must never exceed 80 °C.
 - To clean, rinse the rope with lukewarm water and wipe with a damp cloth. The wet rope should be left to dry before storage. The rope should dry naturally, not near a fire or other heat source.
 - To disinfect the rope, you may only use products that have no influence on the synthetic materials used. If you do not comply with these conditions, you put yourself at risk!
 - A rope swells with use and can shrink in length by up to 15%. Regularly check the length of your rope.
 - A wet or icy rope is less abrasion-resistant. It is also harder to control in belay/rappel devices.
 - A knot at the end of the rope is a necessary precaution in a variety of situations (long rappel, poor visibility, fatigue...). Avoid descending too rapidly: risk of burns and accelerated wear of the rope.
 - To make a termination, tie a figure-eight knot at the desired location on the rope. We recommend a figure eight loop for your own rope terminations. There must be at least 10 cm of rope behind the knot. Please tie the knot correctly, as illustrated in Fig.1! Please note the route the load-bearing portion of rope takes (arrow). A different version will reduce the breaking load considerably.

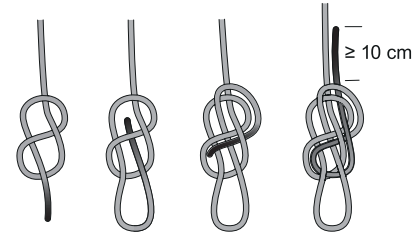
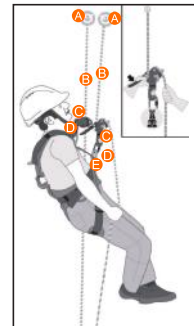

Fig.1 Detail of figure of eight knot

- If free climbing is necessary when using the rope during rope-supported work, rescuing or speleology, you must use suitable ropes (e.g. dynamic mountaineering ropes in accordance with EN 892).
- The system must include a reliable anchoring point (in accordance with EN 795, especially 12KN minimum strength) above the user. Avoid slack in any kernmantle rope with limited elongation between the user and the reliable anchoring point.
- If a rope is cut into several lengths, mark the ends with the correct lengths and end-markings. The new lengths of rope must each be furnished with a copy of the Instructions for Use.

Application:
 The rope shall be used in the following applications:



- key
 A. Anchor points (EN 795)
 B. Ropes (EN 1891)
 C. Descenders (EN 12841)
 D. Connector (EN362)
 E. Full body harness (EN361)

This rope must be used in conjunction with equipment which conform to the European standards (EN361-EN362 - EN795 - EN12841 etc.) and the user need make sure all recommendations of every equipment composing the fall arrest system are understood and applied.

Additional information:
 1. This product meets the requirements of Regulation (EU) 2016/425 on personal protective equipment, and IFU (instructions for use) will be attached to the coil/reel.
 2. Before the product is used there must be a plan for rescue operations that takes into account
 This rope must be used in conjunction with equipment which conform to the European standards (EN361-EN362 - EN795 - EN12841 etc.) and the user need make sure all recommendations of every equipment composing the fall arrest system are understood and applied.

Additional information:
 1. This product meets the requirements of Regulation (EU) 2016/425 on personal protective equipment, and IFU (instructions for use) will be attached to the coil/reel.
 2. Before the product is used there must be a plan for rescue operations that takes into account all possible emergencies. During and before use, you must consider how to perform the rescue efforts safely and effectively.
 3. Do not perform any rope-supported work if your physical condition could compromise your safety during normal use or in an emergency!
 4. In a fall arrest system, it is essential to check the required clearance below the user before each use, in order to avoid hitting the ground or an obstacle in case of a fall. Avoid slack in the rope between the user and the anchor point.
 5. According to EN 1891, no changes or additions to ropes are permitted and may only be performed by the manufacturer. The breaking load of the rope / rope with terminations applies only to force between one of the end of the rope and the other. You should therefore never load a termination loop transversely (2 carabiners in a loop). Check the load on the rope in the selected configuration and never overload it. We recommend a safety factor of ≥ 7.
 6. Make sure that the anchor point is correctly positioned, in order to limit the risk and the length of a fall.
 7. A fall arrest harness is the only device allowable for supporting the body in a fall arrest system.
 8. The Instructions for Use for each item of equipment used in conjunction with this product must be followed.
 9. The Instructions for Use must be provided to the user of this equipment, in the language of the country where the equipment is used. And make sure the markings on the product are legible.

Hoater Guarantee:
 This product is guaranteed for 3 years against any faults in materials or manufacture. Exclusions from the guarantee: normal wear and tear, modifications or alterations, incorrect storage, poor maintenance, damage due to accidents, to negligence, or to improper or incorrect usage.

Declaration of conformity:

Declaration of conformity for rope HT-JL012 available on www.hoater.com

Marking:

Internal marking:

Inside the product, there is a traceability streak, which contains information such as the manufacturer name, it meets standards (EN1891:1998), construction material, type of rope and year of manufacture. This mark is located at least once per meter.

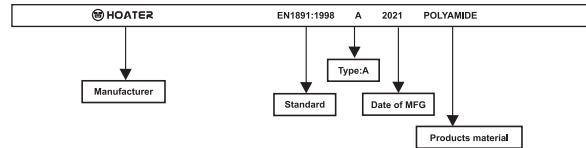

External Marking

Outside the product have an outside marking, which contains information such as product designation, rope type and diameter, it meets standards (EN1891:1998), CE certify, batch number, date of manufacture, trade mark.

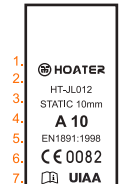

1. Brand
2. Products model number
3. Type and diameter of rope
4. The rope standard
5. CE standard
6. The CE mark showing that the product meets the requirements of the Regulation 2016/425
7. Means read instructions is necessity.
8. UIAA tag

Storage and transport:

A) When not in use, store the product in a well-ventilated area away from extremes of temperature and to avoid all necessary preventative requirements where environmental or other factors could affect the condition of components, e.g. damp environment, sharp edges, vibration, ultra-violet degradation.
B) For transporting the rope, it should be packed in a bag of suitable size and not together with any sharp edged tools.

Instructions for periodic examination:

It's very important for regular periodic examinations, as the user's safety depends on the continued efficiency and durability of the equipment, at least do it once a year.
The periodic examination also including the requirement to check the legibility of the product marking. The periodic examinations of the ropes are only to be conducted by a competent person for periodic examination and strictly in accordance with the manufacturer's periodic examination procedures.

Instructions for repair:

The product has no repairable features hence the manufacturer does not allow any repair that can be carried out on the product whatsoever.

Check card:

It is recommended that the product be inspected and examined by a competent person for any damages or failures usually if the need arises but at least once a year. The observations should be recorded in the table below. In case such damages are observed, the product should be replaced immediately.

CHINESE

货号: HT-JL012

制造商: 霍安克 (杭州) 安全技术有限公司
中国浙江省杭州市临安区大园路723号星汇中心3507

欧盟型式检验和生产控制认证机构:

APAVE SUDEUROPE SAS
8 rue Jean Jacques Vernazza - Z.A.C.Saumaty-Séon - CS 60193 - 13322 MARSEILLE CEDEX 16.

该绳索被欧洲法规 2016/425 归类为个人防护设备 (PPE), 并已通过欧洲标准 EN1891:1998 证明符合该法规。

在使用此绳索之前, 请仔细阅读这些说明

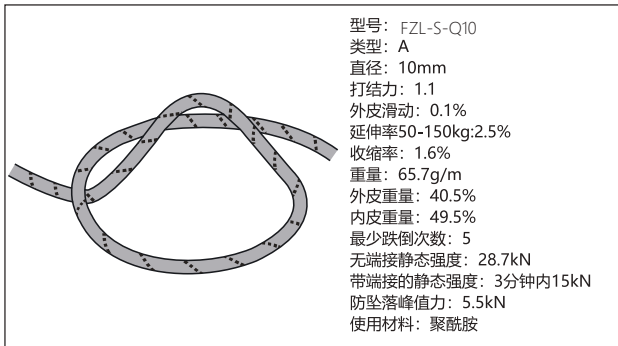

限制:

在使用本设备之前, 请考虑以下应用限制:

1. 设备不得在其限制范围之外使用, 或用于其预期用途以外的任何目的。
2. 设备只能由经过培训并能够安全使用的人员使用。
3. 一次最多可连接一套个人防护系统。
4. 使用前, 监理人员必须考虑可能发生的危险, 制定救援预案, 以应对工作中可能出现的突发事件。
5. 在使用过程中, 用户使用的设备必须在监督下进行。
6. 确保组装到系统中时与设备一起使用的所有其他产品的兼容性。
7. 用户应对设备进行使用前检查, 确保设备处于可使用状态并正常运行后再使用。
8. 如果对设备的安全使用状况有任何疑问或已经停止跌倒, 请停止使用设备, 直到有资格的人员书面确认后才能再次使用。
9. 产品的使用寿命为 10 年, 但每年检查一次很重要, 以检查在使用过程中是否发生任何损坏。
10. 如曾遭受重大跌落或重载, 必须停止使用。
11. 本设备应视为个人物品。

应用领域:

本设备为个人防护设备 --EN1891:1998 A 型静态绳索 (低弹力绳索)。本产品旨在提供防止从高处坠落的风险。该绳索可用于绳索进入、工作定位、旅行约束, 以及救援、探洞或峡谷漂流。也可用作工作绳索或安全绳索。

注意: A 型绳索比 B 型绳索更适合用于绳索进入和工作定位。
如果选择 B 型绳索, 用户应该意识到性能水平会低于 B 型; 需要更加小心地防止磨损、割伤。一般磨损和撕裂等的影响, 并且在使用中应小心谨慎, 以尽量减少跌倒的可能性。

警告

该绳索的负载不得超过其额定强度, 也不得用于其设计用途以外的任何目的。特别是, 不要将它们用于起重。

检查:

1. 您的安全与设备的完整性有关。
2. 根据 EN 365 用于工作安全的设备必须至少每 12 个月由专家或制造商自行检查一次并严格遵守说明, 并在必要时进行更换。
3. 在您的 PPE 检验表上记录检验结果 (见表 1): 类型、型号、商品名称、标识号、制造商联系方式、日期: 制造、购买、首次使用、进入原因 (定期检查或维修)、发现的缺陷、进行的维修和其他相关信息、主管人员的姓名和签名、定期检查下一个到期日。
4. 一般, 检查必须包括:
检查产品的一般状况: 年龄、完整性、污染成分。
标签检查: 标签是否存在? 标签是否清晰? 有 CE 标签吗? 你能读懂 MFG 的日期吗? 检查所有单个零件是否有机械损坏, 例如 撕裂、裂口、划痕、磨损、变形、罗纹、缠结、压碎。检查所有单个零件的热损伤或化学损伤, 例如: 熔化、硬化。
5. 每次使用前, 目视检查绳索整个长度的护套状况。确保没有割伤、烧伤、磨损的股线、模糊区域或化学品迹象。
6. 沿着绳子的整个长度对芯子进行触觉检查, 这样您就可以检测到芯子损坏的区域 (硬点、糊状区域)。
7. 如果设备因跌落而承压, 应立即停止使用。如果您有任何疑问, 该产品必须丢弃, 或者只有在专家提供书面确认经检查后适合使用的情况下才能再次使用。
8. 使用期间: 定期监测产品的状况及其与系统中其他设备的连接非常重要。确保所有设备项目相对于彼此正确定位。

兼容性:

1. 请确保遵守与其他组件一起使用的建议: 工作线束的所有其他组件必须经过认证并符合 PPE 的相关标准
2. 使用符合 EN 1891 的绳索必须在符合 EN 341 (救援下降装置)、EN 358 (工作定位安全带) 或 EN 363 (个人坠落保护系统) 的系统中使用, 即用于各种绳索支撑工作。请注意, 新的、未使用过的绳索的表面可能非常光滑和滑。使用设备时, 请阅读相应设备上的制造商信息。
3. 绳索装置应根据绳索直径进行调整。
4. 金属部件不得有任何可能损坏绳索的毛刺或锋利边缘。任何影响任何单个设备或整个系统安全运行的设备组合也会使您处于危险之中!

使用注意事项

1. B 型绳索的性能水平低于 A 型绳索; 它们更容易受到磨损、割伤、正常磨损.....重要的是要更加注意减少跌倒的可能性。A 型绳索比 B 型绳索更适合用于绳索进入和工作定位。
2. 为了延长绳索的使用寿命 (更好的外皮 / 芯内聚力), 在首次使用前将其浸泡在水中 24 小时。这可以去掉制造过程中使用的润滑剂和其他产品。让绳子慢慢晾干。它将收缩大约 5% (每 100 m 收缩 5 m)。
3. 防止化学品、热、磨损、紫外线。可能损坏绳索的锋利边缘。
4. 两根绳索通过登山扣或邮包摩擦在一起会产生热量, 从而导致破裂。
5. 避免过快的绳索下降或下降, 否则可能会烧毁绳索并加速护套磨损。聚酰胺的熔融温度为 230°C。在非常快速的下降过程中可能会达到这个温度。
6. 绳索使用温度不得超过 80°C。
7. 要清洁, 用温水冲洗绳索, 然后用湿布擦拭。湿绳在存放前应晾干。绳索应自然干燥, 不要靠近火源或其他热源。
8. 对绳索进行消毒时, 只能使用对所用合成材料无影响的产品。如果您不遵守这些条件, 您将处于危险之中!
9. 绳索随着使用而膨胀, 长度最多可收缩 15%。定期检查绳子的长度。
10. 潮湿或结冰的绳索耐磨性较差。在保护 / 绳索设备中也更难控制。
11. 在各种情况下 (长绳索、能见度差、疲劳.....), 绳子末端的结是必要的预防措施。避免下降过快: 有烧伤和加速绳索磨损的风险。
12. 要进行终止, 请在绳索的所需位置打一个 8 字形结。我们建议您为自己的绳索端接使用 8 字形环。绳结后面必须有至少 10 厘米的绳索。请正确打结, 如图 1 所示! 请注意绳索的承重部分走的路线 (箭头)。不同的版本将大大降低断裂载荷。

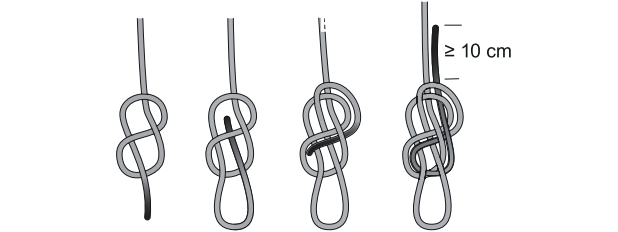
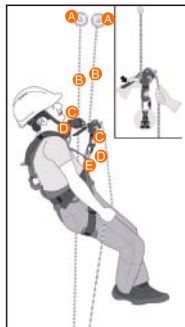

Fig.1 Detail of figure of eight knot

13. 如果在绳索支撑工作、救援或洞穴六中使用绳索时需要自由攀登, 则必须使用合适的绳索 (例如, 符合 EN 892 的动态登山绳索)。
14. 系统必须在用户上方包括一个可靠的锚固点 (根据 EN 795, 尤其是 12KN 最小强度)。避免在用户和可靠锚固点之间伸长有限的任何 kernmantle 绳索松弛。
15. 如果绳子被切成几段, 用正确的长度和末端标记标记末端。每根新的绳索都必须附有使用说明的副本。

应用

绳索应用于以下用途:



关键点

- A. 锚点 (EN 795)
- B. 绳索 (EN 1891)
- C. 下降器 (EN 12841)
- D. 连接器 (EN362)
- E. 全身安全带 (EN361)

该绳索必须与符合欧洲标准 (EN361-EN362 - EN795 - EN12841 等) 的设备一起使用, 并且用户需要确保了解和应用构成防坠落系统的每个设备的所有建议。

附加信息

1. 本产品符合欧盟法规 (EU) 2016/425 对个人防护设备的要求, 并在线圈 / 卷盘上附有 IFU (使用说明)。
2. 在使用产品之前, 必须有一个考虑到所有可能的紧急情况的救援行动计划。在使用过程中和使用之前, 您必须考虑如何安全地进行救援工作。
3. 如果您的身体状况在正常使用或紧急情况下可能危及您的安全, 请勿进行任何绳索支撑工作!
4. 在防坠落系统中, 每次使用前必须检查用户下方所需的间隙, 以免坠落时撞到地面或障碍物。避免用户和锚点之间的绳索松弛。
5. 根据 EN 1891, 不允许对绳索进行更改或添加, 并且只能由制造商执行。绳索 / 带末端的绳索的断裂载荷仅适用于绳索一端与另一端之间的力。因此, 您不应该横向加载终端环 (一个环中有 2 个登山扣)。检查所选配置中绳索上的负载, 切勿使其过载。我们建议安全系数 ≥ 7。
6. 确保锚点位置正确, 以限制跌倒的风险和长度。
7. 防坠落安全带是唯一允许在防坠落系统中支撑身体的装置。
8. 必须遵守与本产品一起使用的每项设备的使用说明。
9. 必须使用设备所在国家 / 地区的语言向本设备的用户提供使用说明。并确保产品上的标记清晰易读。

HOATER 保证

本产品质保 3 年, 不会出现任何材料或制造缺陷。保修范围不包括: 正常磨损、修改或更改、不正确的存储、维护不善、由于事故、疏忽或不正确或不正确的使用造成的损坏。

符合性声明

www.hoater.com 上提供绳索 HT-JL012 的符合性声明

标记

内部标记:

产品内部有一条可追溯性条纹, 其中包含制造商名称、符合标准 (EN1891:1998)、结构材料、绳索类型和制造年份等信息。此标记每米至少出现一次。

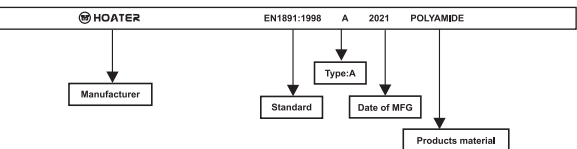

外部标记

产品外部有一个外部标记, 包含产品名称、绳索类型和直径等信息, 符合标准 (EN1891:1998)、CE 认证、批号、生产日期、商标。

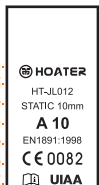

1. 品牌
2. 产品型号
3. 绳索的种类和直径
4. 绳子的标准
5. CE 标准
6. CE 标志表明产品符合法规 2016/425 的要求
7. 意味着阅读说明是必要的。
8. UIAA 标记

储存和运输

A) 不使用时, 将产品存放在通风良好的地方, 远离极端温度, 并避免环境或其他因素可能影响组件状况的所有必要预防要求, 例如潮湿环境、锋利边缘、振动、紫外线降解。
B) 运输绳索时, 应装在大小合适的袋子中, 不要与任何锋利的工具一起运输。

定期检查说明:

定期检查非常重要, 因为用户的安全取决于设备的持续效率和耐用性, 至少每年进行一次。
定期检查还包括要求检查产品标记的易读性。
钢丝绳的定期检查只能由合格的定期检查人员进行, 并严格按照制造商的定期检查程序进行。

维修说明:

该产品没有可修复的功能, 因此制造商不允许对产品进行任何维修。

检查卡

建议通常在需要时由合格人员检查和检查产品是否有任何损坏或故障, 但至少每年一次。观察结果应记录在下表中。如果发现此类损坏, 应立即更换产品。

识别及保修证书 Identification and warranty certificate			
产品类型: Product type			
产品型号: Product number			
制造年份: Year of manufacture			
购买日期: Purchase date			
购买自: Purchased from			
首次使用日期: Date of first use			
监管者: Regulators			
使用者: User:			
公司机构: Company			
注释: Comments			
本文件附属于本产品或使用系统 This documentation should be issued with and kept for each item or system			

定期检查 / 每 3 个月例行检查 Regular inspection/routine inspection every 3 months			
日期 Date	结果 Decision	检查者 Inspector	下次检查日期 Next inspecting
本文件附属于本产品或使用系统 This documentation should be issued with and kept for each item or system			